

Assembly Instructions for Economy & Beamatic™ Screens

No
Tools
Needed!

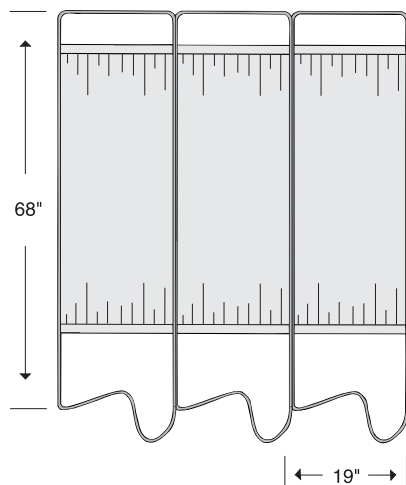
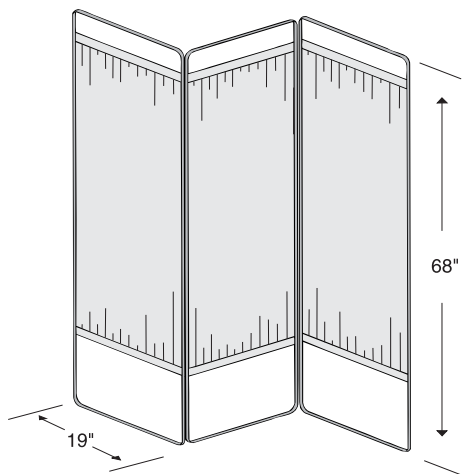

1. Remove All Parts From Carton.
2. Unfold Hinged Top and Bottom Screen Sections.
3. Place Hinged Top Section onto the Bottom Section of Matching Color Coded Dot. Remove Colored Dot. (Figure 1)
4. Unfold Vinyl/Cloth Panels, Then Insert a Screen Panel Rod Through the Pocket at the Top and Bottom of Each Panel. Gather the Panels so that Both Ends of the Rod are Exposed. (Figure 2)
5. With the Vinyl/Cloth Panels Assembled, Insert a Screen Panel Rod in the Holes Provided Near the Top of the Screen Frame. (Figure 3)
6. Pulling the Panel Taut, Insert the Bottom Rod into the Holes Provided Near the Bottom of the Screen Frame.
7. Repeat Steps Five and Six for Each Screen Section.

Your Screen is Now Ready for Use.

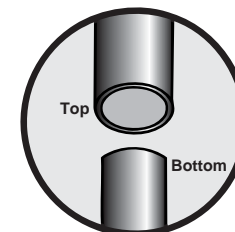

Figure 1

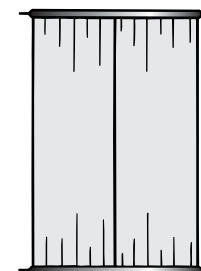

Figure 2

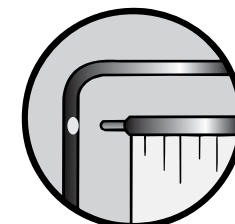

Figure 3

Screen Parts Per Carton For Each Model:

Cat. Number 153052



2 PC. Assembly Top Section



2 PC. Assembly Bottom Section



Vinyl/Cloth Panel 2 ea.
Sold Separately

— Screen Rods 4 ea.

Cat. Number 153053



3 PC. Assembly Top Section

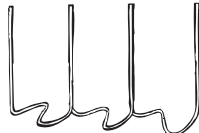

3 PC. Assembly Bottom Section



Vinyl/Cloth Panel 3 ea.
Sold Separately

— Screen Rods 6 ea.

Cat. Number 153054



4 PC. Assembly Top Section

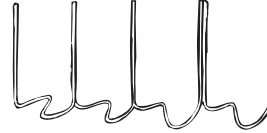

4 PC. Assembly Bottom Section



Vinyl/Cloth Panel 4 ea.
Sold Separately

— Screen Rods 8 ea.

Cat. Number 153055



5 PC. Assembly Top Section

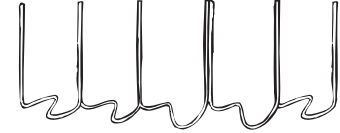

5 PC. Assembly Bottom Section



Vinyl/Cloth Panel 5 ea.
Sold Separately

— Screen Rods 10 ea.

Cat. Number 153092



2 PC. Assembly Top Section

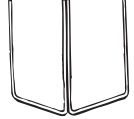

2 PC. Assembly Bottom Section



Vinyl/Cloth Panel 2 ea.
Sold Separately

— Screen Rods 4 ea.

Cat. Number 153093

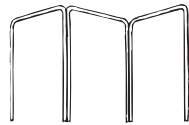

3 PC. Assembly Top Section

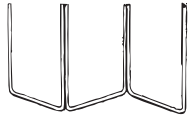

3 PC. Assembly Bottom Section



Vinyl/Cloth Panel 3 ea.
Sold Separately

— Screen Rods 6 ea.

Cat. Number 153094

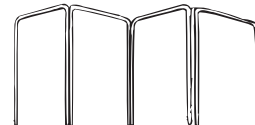

4 PC. Assembly Top Section



4 PC. Assembly Bottom Section



Vinyl/Cloth Panel 4 ea.
Sold Separately

— Screen Rods 8 ea.



800 GLEN AVENUE, P.O. BOX 446
MOORESTOWN, NEW JERSEY 08057

1.800.257.BEAM (2326)
FAX: 1.856.482.2249

E-MAIL: info@omnimedbeam.com
WEB SITE: www.omnimedbeam.com